

Programmable time delay relays CX-30

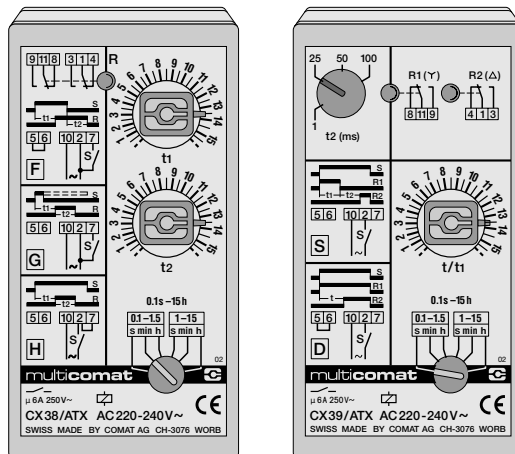

Electronic time delay relays of the series CX-30 point out the following main characteristics:

- Plug in industrial time delay relays with voltage control operation on 2 delayed change-over contacts 6A, 250V~
- 11 pin submagnal plug as specification IEC 67-1-18a
- Timing modes programmable by means of a link on the relay base
- Suitable for front panel mounting with accessory FZ-23
- Digital time circuit comprising RC oscillator and frequency divider
- LED display of the relay function

KÜHN

Kühn Controls S.L.
Vertriebsbüro Deutschland
Gräfenhäuser Str. 14
D-75305 Neuenbürg
Tel.: +49- (0)7082-940000
Fax: +49- (0)7082-940001
eMail: sales@kuehn-controls.de
www.multicomat.net

comat
INDUSTRIELLE ELEKTRONIK

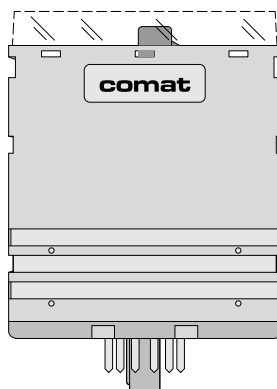

multiCOMAT programmable time delay relays are at work, world wide in all spheres of industry.

CX 38



Data at $T_{amb.} = 25^{\circ}\text{C}$ and $V_{nom.}$

Type	Time range	Partial range		
		0,1–1,5 s	0,1–1,5 min	0,1–1,5 h
CX 38	0,1 s – 15 h	1–15 s	1–15 min	1–15 h
The partial ranges are programmable at the range switch				

Voltages		Current consumption		
Designation	Tolerances	I max. AC	I max. DC	
ATX: 220–240V~ AC 50/60 Hz	-15/+10%	20 mA		
ANP: 110–120V~ AC 50/60 Hz	-15/+15%	35 mA		
UFK: 24–48V≈ AC 40/60 Hz or DC	-20/+25%	55 mA	35 mA	
DNX: 110–240V= DC	-15/+10%		15 mA	
UCB: 12V≈ AC 40/60 Hz or DC	-20/+25%	400 mA	400 mA	

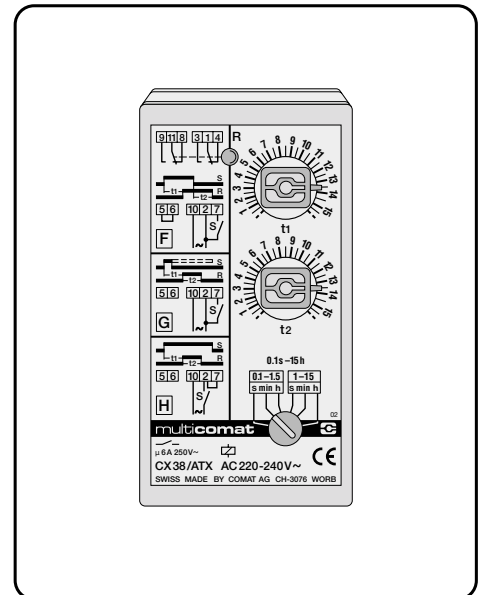
Instead of contact S, executions ATX and ANP can also be driven by two wire proximity switches for AC specified by a max. leakage current of 3mA and a min. load current of 5mA.

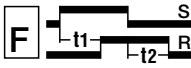
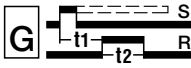
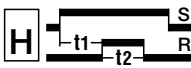

Timing modes	Code	Diagram	Description
On and off delay	F		After driving by S, R energizes according to t1 and releases according to t2 after switching out of S.
On delay - single shot (constant or mom. pulse)	G		After driving by S (momentary or continuous) R energizes after t1 for the set time t2.
On delay - single shot (pulse limitation)	H		After driving by S, R energizes after t1 for the set time t2. R falls back again when S switches out prematurely.
			S = Drive R = Output circuit

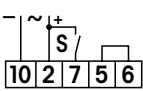
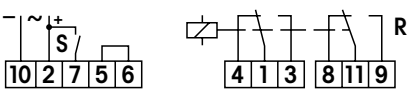
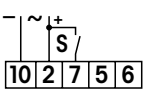
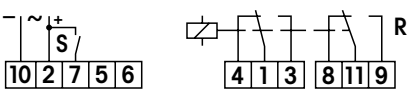
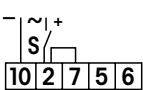
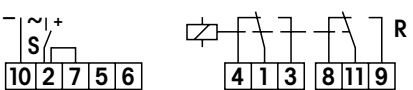
Connection scheme	
	
	
	

Technical data	General
Repeat accuracy ¹⁾	±0,5 % or ±15ms
Voltage stability	±0,5 % ²⁾
Temperature stability	±0,1 %/°C
Time range tolerance t min.	-20 ÷ +0 %
Time range tolerance t max.	-0 ÷ +15 %
Duty cycle	ED=100 %
Reset time during t	70ms
Reset time after time expiry	35ms
Triggering time	≥ 100ms
Triggering delay time	60...100ms
Operating temperature range	-25 ... +60°C
Storage temperature range	-25 ... +80°C
Testing voltage	2 kV, 50Hz, 1min
Specifications	CE, VDE 0435/0110 Gr. C
Protection/case material	IP 40/Noryl SE 1 to UL 94V-1
Weight incl. packing	approx. 170g

¹⁾ referred to the set time
²⁾ max. tolerance total

Technical data	Output circuit
Switching current max.	6A
Switching voltage max.	250V~AC 1
Breaking capacity	AC: 1200VA; DC: ...250W
Mechanical life	2x10 ⁷ operations
Contact material	Ag Ni

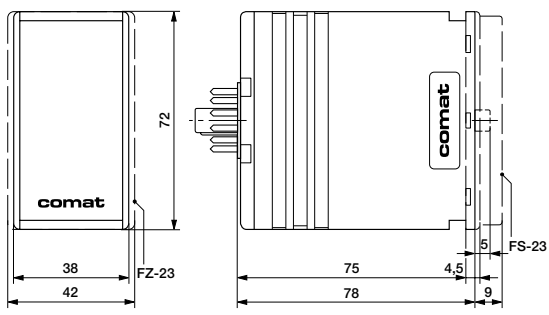
Dimensions	Case S3
	
<p>Front mounting accessory FZ-23 (front panel aperture: 38,5x70^{+0,5} mm, front panel thickness max. 3mm). Transparent front cover FS-23 (part of the scope of delivery).</p>	

Data at Tamb. = 25°C and Vnom.

Type	Time range	Partial range			
CX 39	0,1 s – 15 h (t/t1)	0,1–1,5 s	0,1–1,5 min	0,1–1,5 h	
		1–15 s	1–15 min	1–15 h	
(Star-delta function)	1–100 ms (t2)	1 ms	25 ms	50 ms	100 ms

The partial ranges are programmable at the range switch

Voltages		Current consumption		
Designation		Tolerances	I max. AC	I max. DC
ATX: 220–240V~	AC 50/60 Hz	-15/+10%	17 mA	
ANP: 110–120V~	AC 50/60 Hz	-15/+15%	35 mA	
UFK: 24–48V≈	AC 40/60 Hz or DC	-20/+25%	80 mA	40 mA
DNX: 110–240V=	DC	-15/+10%		25 mA
UCB: 12V≈	AC 40/60 Hz or DC	-20/+25%	350 mA	450 mA

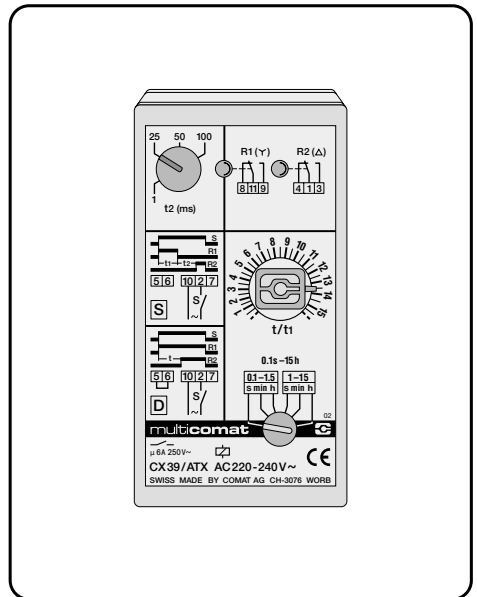

Timing modes	Code	Diagram	Description
On delay with one shot leading edge contact (Star-delta function)	S		After driving by S, R1 energizes according to t1 and R2 after t2 when R2 falls back. (Star-delta function). R1 and R2 fall back when S switches out prematurely.
On delay with instantaneous contact	D		After driving by S, R1 energizes immediately and R2 according to t. R1 and R2 fall back when S switches out prematurely.
			S = Drive R = Output circuit

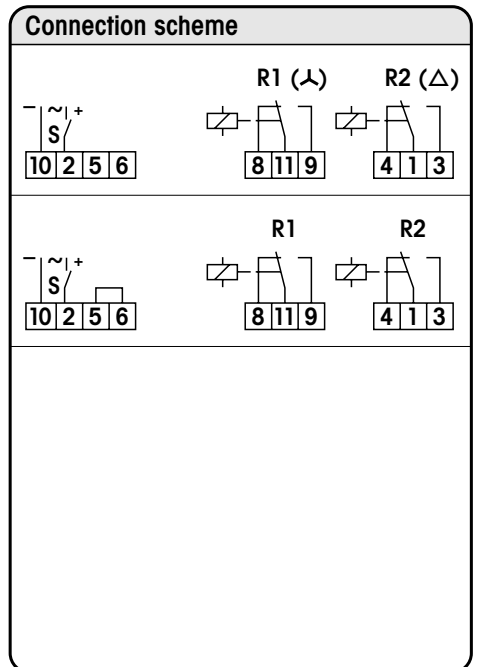

Technical Data	General
Repeat accuracy ¹⁾	±0,5 % or ±15 ms
Voltage stability	±0,5 % ²⁾
Temperature stability	±0,1 %/°C
Time range tolerance t min.	-20 ÷ +0 %
Time range tolerance t max.	-0 ÷ +15 %
Duty cycle	ED=100 %
Reset time during t	70 ms
Reset time after time expiry	35 ms
Operating temperature range	-25 ... +60°C
Storage temperature range	-25 ... +80°C
Testing voltage	2 kV, 50 Hz, 1 min
Specifications	CE, VDE 0435/0110 Gr.C
Protection/case material	IP 40/Noryl SE 1 to UL 94 V-1
Weight incl. packing	approx. 230 g

¹⁾ referred to the set time
²⁾ max. tolerance total

Technical data	Output circuit
Switching current max.	6A
Switching voltage max.	250V~ AC1
Breaking capacity	AC: 1200VA; DC: ...250W
Mechanical life	2x10 ⁷ operations
Contact material	Ag Ni

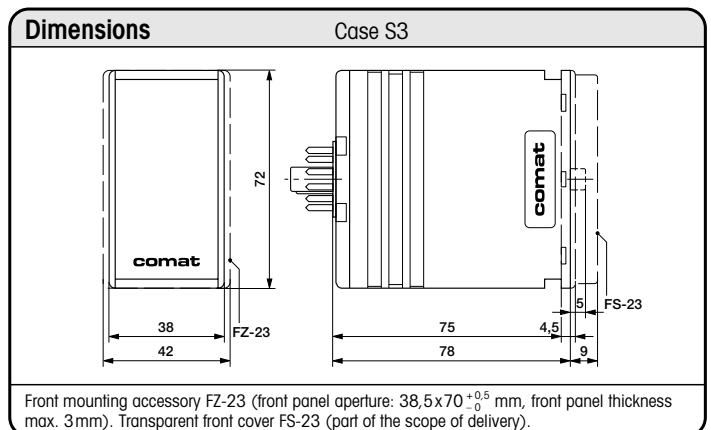

C11A Relay socket with screw, connections for panel or DIN mounting-snap fit

Technical drawing of relay socket C11A. Front view shows a 38x75mm footprint with 12 terminals (1-12) and labels for M3, M4, A2-CONNECTOR, SC-3, and SD-1. Side view shows a height of 20mm and a mounting tab of 4mm. Labels include LH-1, L-16, and C-A2.

EC-11 Relay socket with screw, connections for panel or DIN mounting-snap fit

Technical drawing of relay socket EC-11. Front view shows a 38x62mm footprint with 12 terminals (1-12) and labels for M3, M4, and A2. Side view shows a height of 24.2mm and a mounting tab of 4mm.

CS-11 Relay socket with screw, connections for panel or DIN mounting-snap fit

Technical drawing of relay socket CS-11. Front view shows a 38x68mm footprint with 12 terminals (1-12) and labels for M3, M4, A2, A1, and A14. Side view shows a height of 20mm and a mounting tab of 4mm. Labels include LABEL SL-36, CODING CA-11, and TS 35.

11 PGF Relay socket for fasten connectors (2x2,8x0,8 DIN 46247)

Technical drawing of relay socket 11 PGF. Front view shows a 38x39mm footprint with 4 terminals and labels for Faston 2,8x0,8 (2x). Side view shows a height of 10mm and a mounting tab of 6.5mm.

RG-23 Surface mounting case with built-in relay socket (protected connection terminals)

Technical drawing of surface mounting case RG-23. Front view shows a 50x125mm footprint with 12 terminals and labels for M3, M4, A2, A1, and A14. Side view shows a height of 97mm and a mounting tab of 24mm.

Blank technical drawing area.

11 PGL Relay socket for chassis mounting (solder tags = 3,8x0,8 mm)

Technical drawing of relay socket 11 PGL. Front view shows a 38x39mm footprint with 4 terminals and labels for Faston 3,8x0,8. Side view shows a height of 10mm and a mounting tab of 11mm.

HF-24 Retaining clip for cases S2, S3, S4, suitable for all relay sockets

Technical drawing of retaining clip HF-24. Dimensions include 46mm length, 35mm width, 14mm height, and 0.6mm thickness.

FS-23 Transparent cover (always included with the relay)

3D perspective drawing of transparent cover FS-23, showing its rectangular shape and mounting points.

Blank technical drawing area.

FZ-23 Front of panel mounting accessory comprising 2 front frame parts ① and 2 retaining clips ②

Technical drawing of front of panel mounting accessory FZ-23. It shows the assembly of two front frame parts (1) and two retaining clips (2) onto a panel. Dimensions include 70mm height, 38.5mm width, and a minimum panel thickness of 4.8mm. Labels include Gehäuse case, boîtier S3.