

Programmable time delay relays RS-20

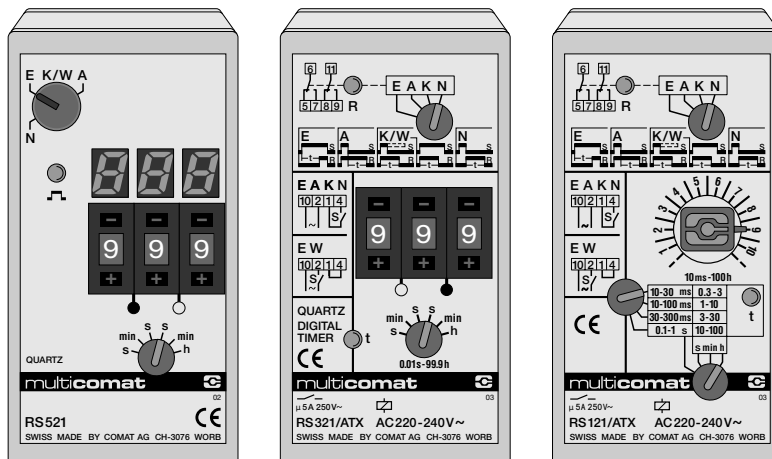

- This leaflet describes the RS-20 series of electronic time delay relays.
- As a separate product group within the multiCOMAT time delay relay programme, they meet the most demanding requirements of flexibility, quality and reliability.
- Due to the fact that programmes can be drawn up to fully match the conditions of the task in hand, the series RS-20 offers the user maximum flexibility and a wide range of application possibilities coupled with a high degree of ease of operation.
- The unusually broad spectrum of functions, time delay ranges and voltages is concentrated into a limited number of types only.
- Arising out of this development, stocks can be held to a minimum, giving numerous servicing advantages. In addition, the best possible opportunity exists to match the particular end use to the most suitable type of apparatus.



Kühn Controls S.L.
 Vertriebsbüro Deutschland
 Gräfenhäuser Str. 14
 D-75305 Neuenbürg
 Tel.: +49- (0)7082-940000
 Fax: +49- (0)7082-940001
 eMail: sales@kuehn-controls.de
 www.multicomat.net

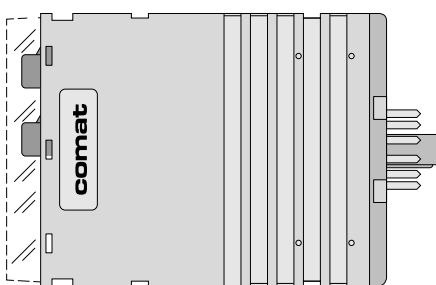

Type	Time range	Partial range		
		sec	min	h
RS 521	0,01 s – 99,9 h	0,01 – 9,99 s	0,1 – 99,9 min	0,1 – 99,9 h
		0,1 – 99,9 s	1 – 999 min	
		1 – 999 s		

The partial ranges are programmable at the range switch

Voltages, current consumption, type			
	AC 50/60 Hz / DC		
	U min – U max	I max	Ordering no.
AC 110–240V~	90–265V	30 mA	RS 521/ANX
UC 24–48V≈	19–60V	160 mA	RS 521/UFK
DC 110–240V=	19–60V	250 mA	RS 521/DNX

Example of order: 1 time delay relay RS 521/ANX

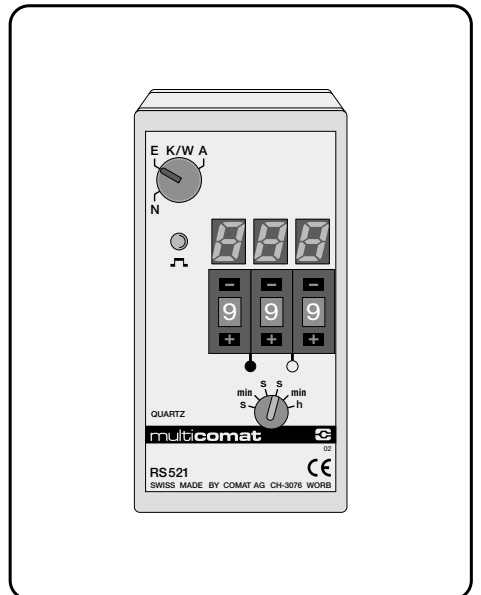

Timing modes	Diagram	Description	Scheme
On delay		S ⇒ R on with delay SOFF ⇒ R off	① ②
Off delay		S ⇒ R on SOFF ⇒ R off with delay	②
Pulse shaping		S (pulse or continuous contact) ⇒ R on for t S --- does not influence R and t	②
One shot leading edge		S ⇒ R on for t SOFF ⇒ R off (pulse clipping)	①
One shot trailing edge		SOFF ⇒ R on for t S on for t ⇒ R off	②
Time stop		Sstop interrupts t (t-addition)	

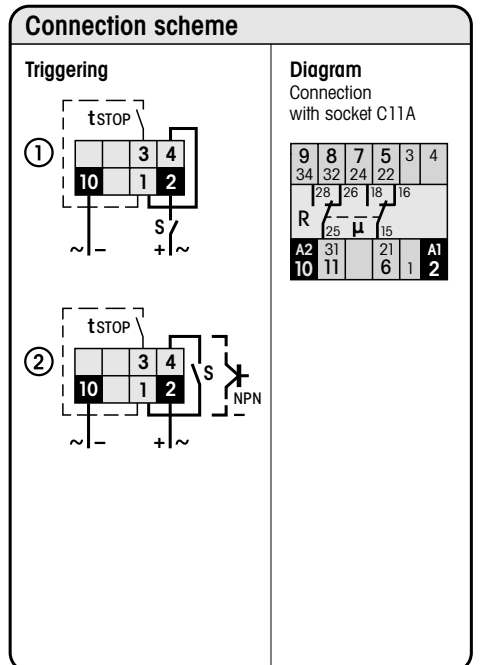

Technical data	General
Repeat accuracy ¹⁾	±0,01 % or ±1,5 % (10)ms
Voltage stability	±1,5ms/10 % ΔTamb
Temperature stability	0,1 ppm/°C ΔTamb
Time range tolerance max.	±0,05 %
Setting accuracy	±0,05 %
Reset time during time expiry	10 (50)ms
Reset time after time expiry	5 (25)ms
Triggering time	≥ 10ms
Triggering delay time	5... 10ms
Load of control contact S	12V~, 6mA
Control line max.	200Ω, 0,1μF/1 Volt
Operating temperature range	-20... +60°C
Storage temperature range	-20... +80°C
Transient voltage protection	IEC 255.4, app. E, Kl. III
Specifications/Standards	VDE 0435/0110 Gr.C, CE
Protection/Case material	IP 40/Noryl SE1 to UL 94V-1
Weight incl. packing	approx. 200g

¹⁾ referred to the set time () = with voltage control operation as scheme 1
Data at $T_{amb} = 25^{\circ}\text{C}$ and V_{nom}

Technical data	Output circuit
Switching current max.	5A
Switching voltage max.	250V~ AC 1
Breaking capacity	AC: 1200VA; DC: 35-250W
Mechanical life	3x10 ⁷ operations
Contact material	Ag Ni

These values are valid for ohmic load or for inductive loading with spark arrest.

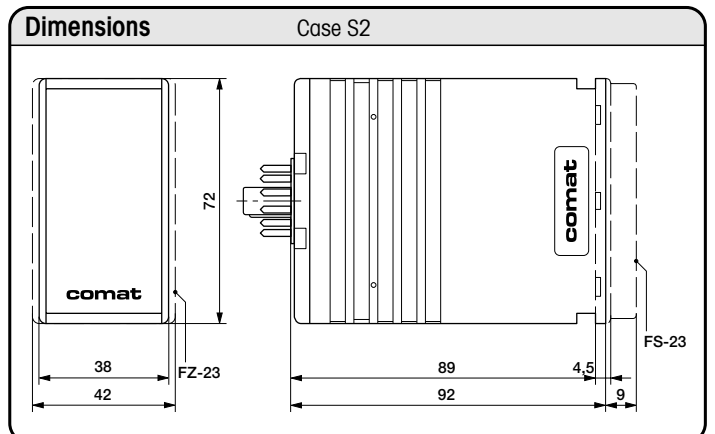

Type	Time range	Partial range		
		sec	min	h
RS 321	0,01 s – 99,9 h	0,01 – 9,99 s	0,1 – 99,9 min	0,1 – 99,9 h
		0,1 – 99,9 s	1 – 999 min	
		1 – 999 s		

The partial ranges are programmable at the range switch

Voltages, current consumption, type			
	AC 50/60 Hz / DC		
	U min – U max	I max	Ordering no.
AC 220–240V~	-15% – +10%	17 mA	RS 321/ATX
AC 110–120V~	-15% – +10%	30 mA	RS 321/ANP
UC 24–48V~	-15% – +20%	160 mA	RS 321/UFK
UC 12V~	-15% – +20%	300 mA	RS 321/UCB
DC 110–240V=	-15% – +10%	20 mA	RS 321/DNX

Example of order: 1 time delay relay RS 321/ATX

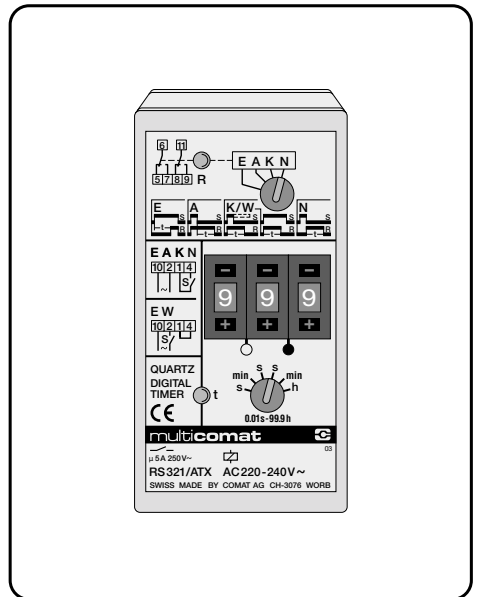

Timing modes	Diagram	Description	Scheme
On delay		S ⇒ R on with delay SOFF ⇒ R off	① ②
Off delay		S ⇒ R on SOFF ⇒ R off with delay	②
Pulse shaping		S (pulse or continuous contact) ⇒ R on for t S --- does not influence R and t	②
One shot leading edge		S ⇒ R on for t SOFF ⇒ R off (pulse clipping)	①
One shot trailing edge		SOFF ⇒ R on for t S on for t ⇒ R off	②

ON OFF S = triggering ⇒ = switches... R = output circuit

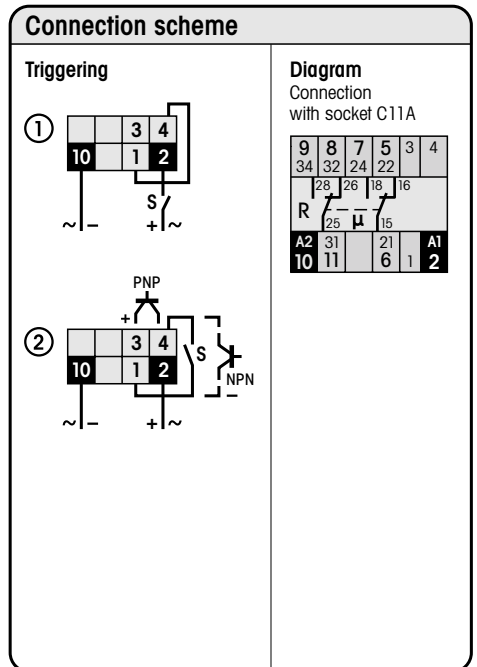

Technical data	General
Repeat accuracy ¹⁾	±0,01% or ±1,5% (10) ms
Voltage stability	±1,5% ms/10% ΔTamb
Temperature stability	0,1 ppm/°C ΔTamb
Time range tolerance max.	±0,5%
Setting accuracy	±0,5%
Reset time during time expiry	10 (50) ms
Reset time after time expiry	5 (25) ms
Triggering time	≥ 10 ms
Triggering delay time	5...10 ms
Load of control contact S	20V~, 10 mA/300 mA/1 ms
Control line max.	100Ω, 0,1μF
Operating temperature range	-20... +60°C ²⁾
Storage temperature range	-20... +80°C
Transient voltage protection	2 kV, 50μs
Specifications/Standards	VDE 0435/0110 Gr. C, CE
Protection/Case material	IP 40/Noryl SE1 to UL 94 V-1
Weight incl. packing	approx. 155 g, ATX and ANP: 240 g

¹⁾ referred to the set time () = with voltage control operation as scheme 1
Data at Tamb = 25°C and Vnom

Technical data	Output circuit
Switching current max.	5A
Switching voltage max.	250V~ AC 1
Breaking capacity	AC: 1200VA; DC: 35-250W
Mechanical life	3x10 ⁷ operations
Contact material	Ag Ni

These values are valid for ohmic load or for inductive loading with spark arrest.

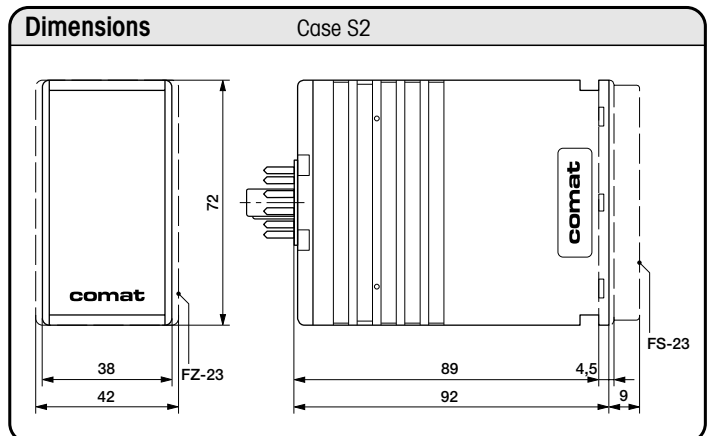

Type	Time range	Partial range			
RS 121 RS 121.P	10 ms – 100 h	10 – 30 ms	0,3 – 3 s	0,3 – 3 min	0,3 – 3 h
		10 – 100 ms	1 – 10 s	1 – 10 min	1 – 10 h
		30 – 300 ms	3 – 30 s	3 – 30 min	3 – 30 h
		100 – 1000 ms	10 – 100 s	10 – 100 min	10 – 100 h

The partial ranges are programmable at the range switch

Voltages, current consumption, type				
Symbol	AC 50/60 Hz / DC		Ordering no.	Ordering no.
	U min – U max	I max		
AC 220–240V~	-15% – +10%	15 mA	RS 121/ATX	RS 121.P/ATX
AC 110–120V~	-15% – +10%	30 mA	RS 121/ANP	RS 121.P/ANP
UC 24–48V≈	-15% – +20%	90 mA	RS 121/UFK	RS 121.P/UFK
UC 12V≈	-15% – +20%	270 mA	RS 121/UCB	---
DC 110–240V≡	-15% – +10%	35 mA	RS 121/DNX	---

Example of order: 1 time delay relay RS 121/ATX

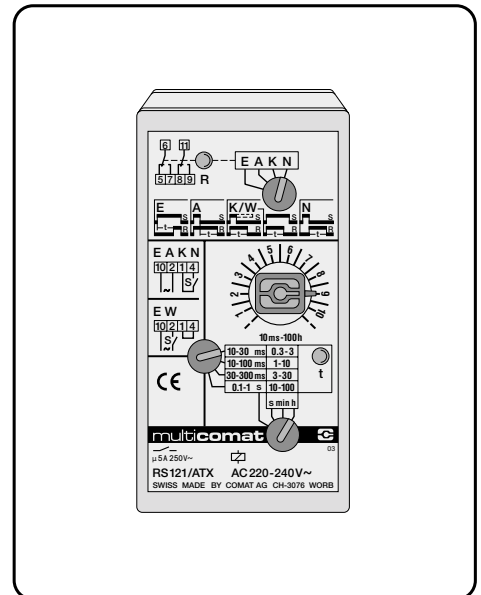

Timing modes	Diagram	Description	Scheme
On delay		S ⇒ R on with delay SOFF ⇒ R off	① ② ③
Off delay		S ⇒ R on SOFF ⇒ R off with delay	② ③
Pulse shaping		S (pulse or continuous contact) ⇒ R on for t S --- does not influence R and t	② ③
One shot leading edge		S ⇒ R on for t SOFF ⇒ R off (pulse clipping)	①
One shot trailing edge		SOFF ⇒ R on for t S on for t ⇒ R off	② ③

ON OFF S = triggering ⇒ = switches... R = output circuit

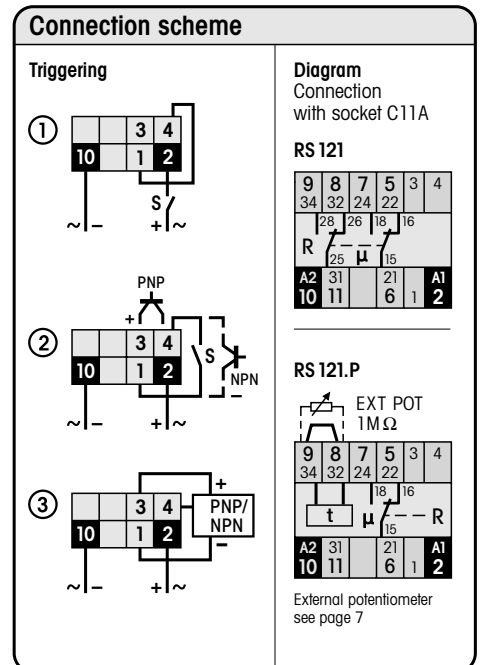

Technical data	General
Repeat accuracy ¹⁾	±0,1% or 2(10)ms
Voltage stability	0,5%/10% ΔTamb
Temperature stability	0,05%/°C ΔTamb
Time range tolerance max.	t max –0 +10%, t min –10% +0%
Remote potentiometer	1 MΩ, lin.
Remote circuit capacity max.	0,1 μF
Reset time during time expiry	10(50)ms
Reset time after time expiry	5(25)ms
Triggering time	≥10ms
Triggering delay time	5...10ms
Load of control contact S	30V~, 15mA
Control line max.	100Ω, 0,1 μF
Supply for sensors 1–3	24V – not stabilized, max. 15mA
Operating temperature range	–20... +60°C ²⁾
Storage temperature range	–20... +80°C
Transient voltage protection	2kV, 50μs
Specifications/Standards	VDE 0435/0110 Gr.C, CE
Protection/Case material	IP 40/Noryl SE 1 to UL 94 V-1
Weight incl. packing	approx. 150g, ATX and ANP: 235g

¹⁾ referred to the set time () = with voltage control operation as scheme 1
²⁾ max. +50°C on scheme 3 Data at Tamb = 25°C and Vnom

Technical data	Output circuit
Switching current max.	5A
Switching voltage max.	250V~AC 1
Breaking capacity	AC: 1200VA; DC: 35-250W
Mechanical life	3x10 ⁷ operations
Contact material	Ag Ni

These values are valid for ohmic load or for inductive loading with spark arrest.

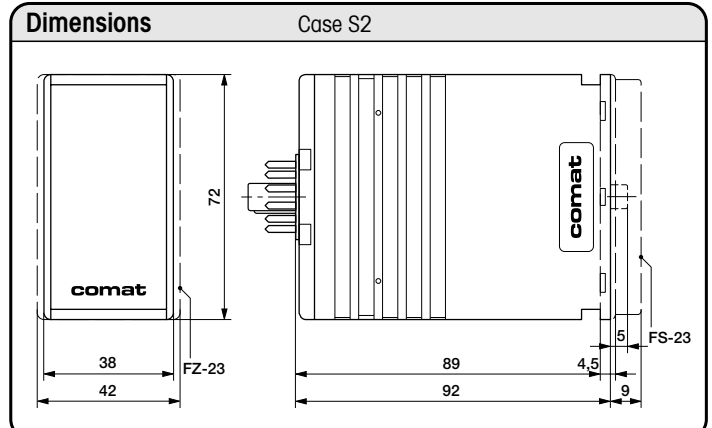

Type	Time range	Partial range			
RS 121.R	10 ms – 100 h	10 – 30 ms	0,3 – 3 s	0,3 – 3 min	0,3 – 3 h
		10 – 100 ms	1 – 10 s	1 – 10 min	1 – 10 h
		30 – 300 ms	3 – 30 s	3 – 30 min	3 – 30 h
		100 – 1000 ms	10 – 100 s	10 – 100 min	10 – 100 h

The partial ranges are programmable at the range switch

Voltages, current consumption, type			
	AC 50/60 Hz / DC		
	U min – U max	I max	Ordering no.
AC 220–240V~	-15% – +10%	15 mA	RS 121.R/ATX
AC 110–120V~	-15% – +10%	30 mA	RS 121.R/ANP
UC 24–48V≈	-15% – +20%	90 mA	RS 121.R/UFK

Example of order: 1 time delay relay RS 121.R/ATX

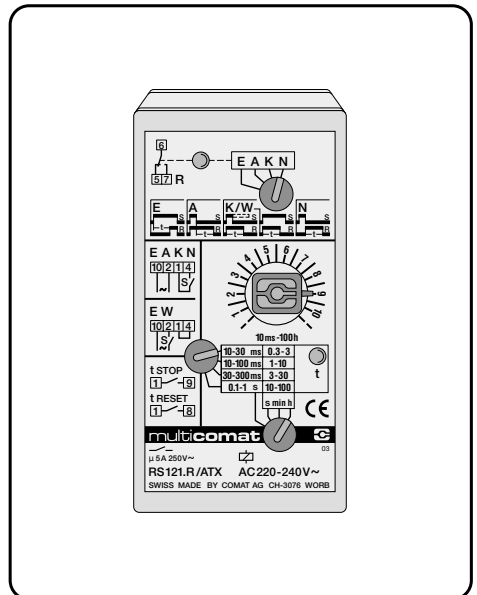

Timing modes	Diagram	Description	Scheme
On delay		S ⇒ R on with delay S _{OFF} ⇒ R off	① ② ③
Off delay		S ⇒ R on S _{OFF} ⇒ R off with delay	② ③
Pulse shaping		S (pulse or continuous contact) ⇒ R on for t S _{OFF} does not influence R and t	② ③
One shot leading edge		S ⇒ R on for t S _{OFF} ⇒ R off (pulse clipping)	①
One shot trailing edge		S _{OFF} ⇒ R on for t S on for t ⇒ R off	② ③
Time reset		S _{RESET} resets t t restarts immediately	
Time stop		S _{STOP} interrupts t (t-addition)	

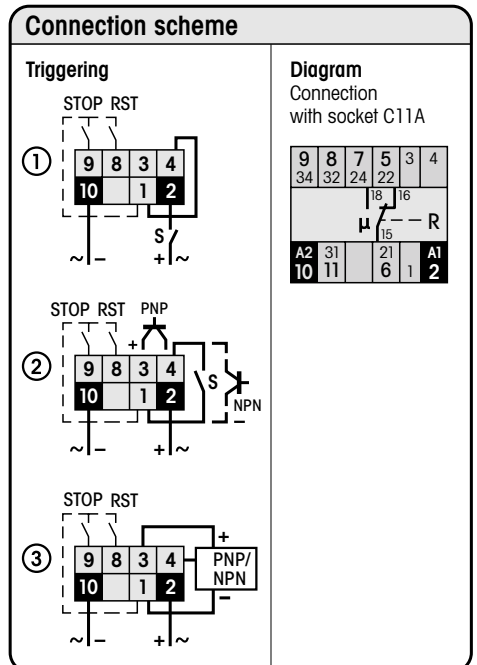

Technical data	General
Repeat accuracy ¹⁾	±0,1% or 2(10)ms
Voltage stability	0,5%/10% ΔTamb
Temperature stability	0,05%/°C ΔTamb
Time range tolerance max.	t max –0 +10%, t min –10% +0%
Reset time during time expiry	10(50)ms
Reset time after time expiry	5(25)ms
Triggering time	≥ 10ms
Triggering delay time	5... 10ms
Load of control contact S	30V~, 15mA
Control line max.	100Ω, 0,1μF
Supply for sensors 1–3	24V – not stabilized, max. 15mA
Operating temperature range	–20... +60°C ²⁾
Storage temperature range	–20... +80°C
Transient voltage protection	2 kV, 50μs
Specifications/Standards	VDE 0435/0110 Gr. C, CE
Protection/Case material	IP 40/Noryl SE1 to UL 94 V-1
Weight incl. packing	approx. 150g, ATX and ANP: 235g

¹⁾ referred to the set time () = with voltage control operation as scheme 1
²⁾ max. +50°C on scheme 3 Data at Tamb = 25°C and Vnom

Technical data	Output circuit
Switching current max.	5A
Switching voltage max.	250V~ AC 1
Breaking capacity	AC: 1200VA; DC: 35-250W
Mechanical life	3x10 ⁷ operations
Contact material	Ag Ni

These values are valid for ohmic load or for inductive loading with spark arrest.

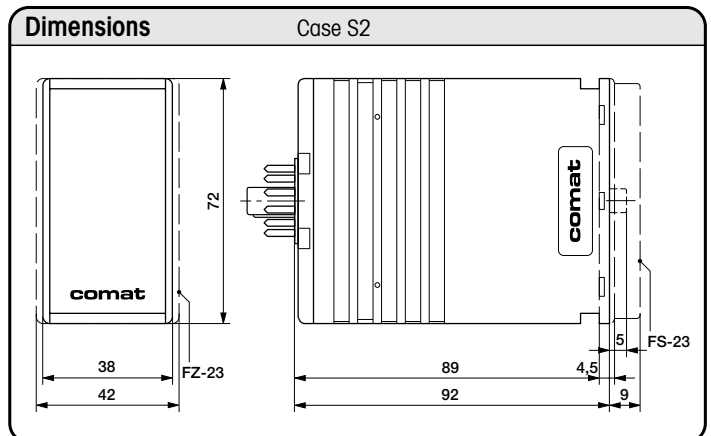

RS 122 -M/-MH/-H

SWISS MADE BY COMAT AG 3076 WORB

Data at Tamb = 25°C and Vnom

Type	Time range		Partial range			
	I	P	Time range → 0,1 s – 30 min	0,1 – 1 s	0,6 – 6 s	3 – 30 s
RS 122-M	0,1 s – 30 min	0,1 s – 30 min	0,1 s – 30 min	0,1 – 1 min	0,6 – 6 min	3 – 30 min
RS 122-MH	0,1 s – 30 min	0,1 min – 30 h	0,1 min – 30 h	0,1 – 1 min	0,6 – 6 min	3 – 30 min
RS 122-H	0,1 min – 30 h	0,1 min – 30 h	0,1 min – 30 h	0,1 – 1 h	0,6 – 6 h	3 – 30 h

Impulse (I) and interval (P) are programmable separately. Example (RS 122-M): I = 0,1 – 1 s, P = 3 – 30 min

Voltages, current consumption, type			
	AC 50/60 Hz / DC		Ordering no. M, MH, H
	U min – U max	I max	
AC 220–240V~	-15% – +10%	15 mA	RS 122-.../ATX
AC 110–120V~	-15% – +10%	30 mA	RS 122-.../ANP
UC 24–48V~	-15% – +20%	90 mA	RS 122-.../U FK
UC 12V~	-15% – +20%	270 mA	RS 122-.../UCB
DC 110–240V=	-15% – +10%	35 mA	RS 122-.../DNX

Example of order: 1 time delay relay RS 122-M/ATX



Timing modes	Diagram	Description	Scheme
Repeat cycle timer pulse start		S ⇒ R on/off periodically according to t1 and t2 SOFF ⇒ R off	①
Repeat cycle timer interval start		S ⇒ R after t1 on/off periodically according to t2 and t1 SOFF ⇒ R off	②

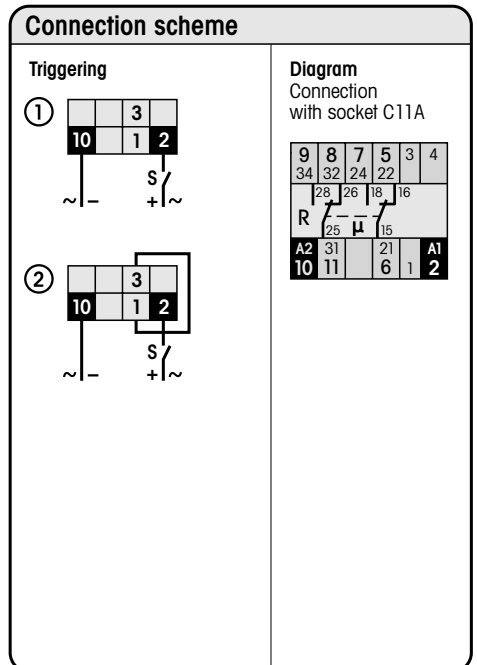

Technical data	General
Repeat accuracy ¹⁾	±0,2% or ±10ms
Voltage stability	0,5%/10% Δ Tamb
Temperature stability	0,1%/°C Δ Tamb
Time range tolerance max.	t max – 0 +10%, t min –10% +0%
Reset time during interval time	150ms
Reset time during pulse time	120ms
Triggering delay time	50ms
Load of control contact S	see voltage table
Operating temperature range	–20... +60°C
Storage temperature range	–20... +80°C
Transient voltage protection	2kV, 50μs
Specifications/Standards	VDE 0435/0110 Gr.C, CE
Protection/Case material	IP 40/Noryl SE1 to UL 94 V-1
Weight incl. packing	approx. 145g, ATX and ANP: 230g

¹⁾ referred to the set time Data at Tamb = 25°C and Vnom

Technical data	Output circuit
Switching current max.	6A
Switching voltage max.	250V~ AC 1
Breaking capacity	AC: 1200VA; DC: 35–250W
Mechanical life	2x10 ⁷ operations
Contact material	Ag Ni

These values are valid for ohmic load or for inductive loading with spark arrest.

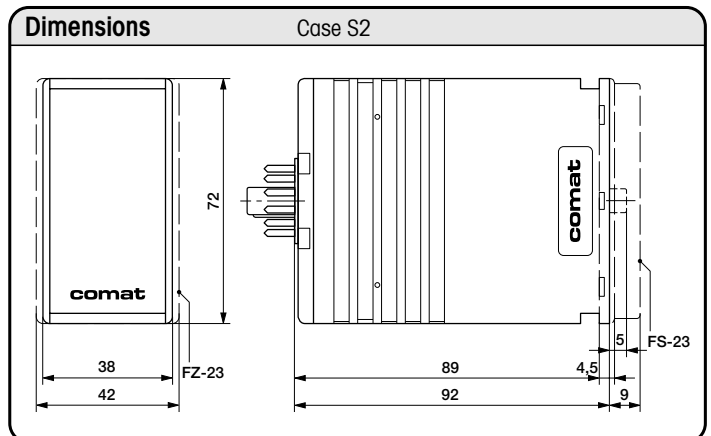

C11A Relay socket with screw, connections for panel or DIN mounting-snap fit

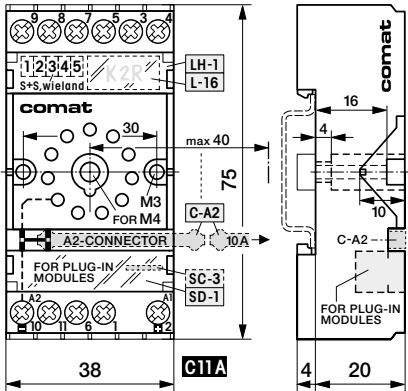

Technical drawing of the C11A relay socket. The front view shows a 38mm wide unit with 12 terminals (1-12) and labels LH-1, L-16, M3 FOR M4, C-A2, SC-3, SD-1, and FOR PLUG-IN MODULES. Dimensions include 30mm, max 40mm, 75mm, 16mm, 4mm, 10mm, 20mm, and 4mm. The side view shows a 20mm depth and a 4mm mounting flange.

EC-11 Relay socket with screw, connections for panel or DIN mounting-snap fit

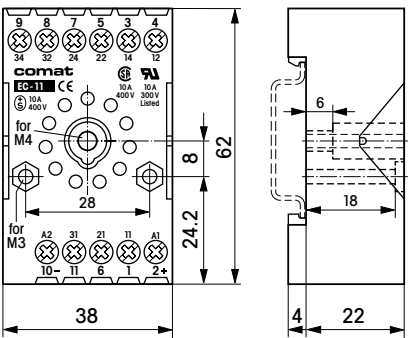

Technical drawing of the EC-11 relay socket. The front view shows a 38mm wide unit with 12 terminals (1-12) and labels 9, 8, 7, 5, 3, 4, 34, 32, 24, 22, 14, 12, comat, EC-11, 10A 300V Listed, 10A 400V, for M4, 28, 8, 62, 24.2, 38, for M3, A2, 31, 21, 11, A1, 14, 10, 11, 6, 2, 4. The side view shows a 22mm depth and a 4mm mounting flange.

CS-11 Relay socket with screw, connections for panel or DIN mounting-snap fit

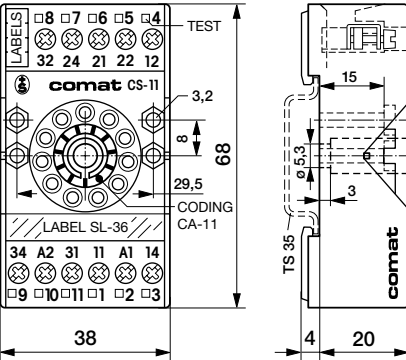

Technical drawing of the CS-11 relay socket. The front view shows a 38mm wide unit with 12 terminals (1-12) and labels 8, 7, 6, 5, 4, TEST, 32, 24, 21, 22, 12, comat, CS-11, 3.2, 8, 68, 29.5, CODING CA-11, LABEL SL-36, 34, A2, 31, 11, A1, 14, 9, 10, 11, 1, 2, 3. The side view shows a 20mm depth and a 4mm mounting flange.

11 PGF Relay socket for fasten connectors (2xAMP 2,8x0,8 DIN 46247)

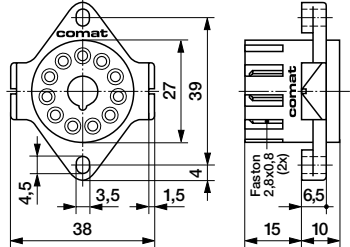

Technical drawing of the 11 PGF relay socket. The front view shows a 38mm wide unit with 12 terminals and dimensions 4.5, 3.5, 1.5, 4, 27, 39. The side view shows a 15mm depth and a 10mm mounting flange, with labels Faston 2,8x0,8 (2x).

RG-23 Surface mounting case with built-in relay socket (protected connection terminals)

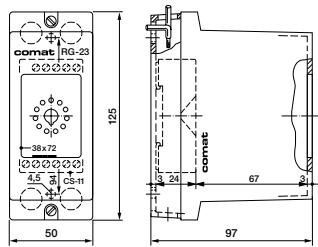

Technical drawing of the RG-23 surface mounting case. The front view shows a 50mm wide unit with 12 terminals and labels comat, RG-23, 38x72, 12, 10, 11, 6, 2, 4, 10A 300V Listed, 10A 400V. The side view shows a 97mm depth and a 24mm mounting flange.

SP-01 External potentiometer (1 M Ω) for remote adjustment of the delay time

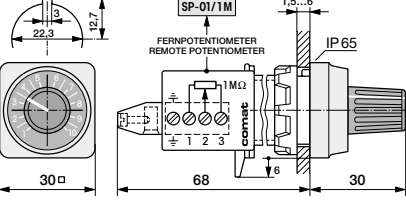

Technical drawing of the SP-01 external potentiometer. The front view shows a 30mm wide unit with a 22.3mm diameter and a 2.7mm height. The side view shows a 68mm length and a 30mm depth, with labels SP-01/1M, FERNPOTENTIOMETER REMOTE POTENTIOMETER, 1M Ω , IP65, 1.5...6, 6, 30, 1, 2, 3.

11 PGL Relay socket for chassis mounting (solder tags = 3,8x0,8 mm)

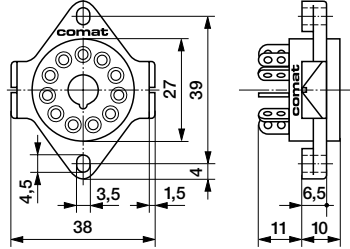

Technical drawing of the 11 PGL relay socket. The front view shows a 38mm wide unit with 12 terminals and dimensions 4.5, 3.5, 1.5, 4, 27, 39. The side view shows a 11mm depth and a 10mm mounting flange.

HF-24 Retaining clip for cases S2, S3, S4 suitable for all relay sockets

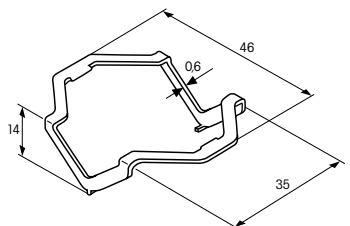

Technical drawing of the HF-24 retaining clip. The drawing shows a 46mm wide clip with a 14mm height and a 35mm length, with a 0.6mm thickness.

FS-23 Transparent cover (always included with the relay)

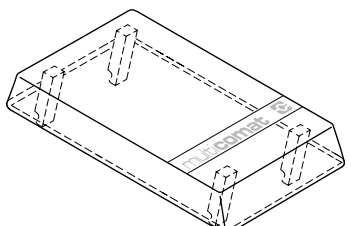

Technical drawing of the FS-23 transparent cover. The drawing shows a rectangular cover with a 38mm width and a 70mm height, with a 1mm thickness.

FZ-23 Front of panel mounting accessory comprising 2 front frame parts ① and 2 retaining clips ②

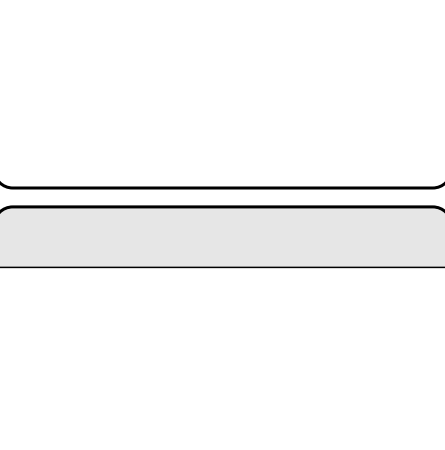

Technical drawing of the FZ-23 front of panel mounting accessory. The drawing shows a 70mm high frame with a 38.5mm width and a minimum 48mm depth. It includes labels 1, 2, 3, 1...3, and Gehäuse case, boîtier S2.

FZ-23 Front of panel mounting accessory comprising 2 front frame parts ① and 2 retaining clips ②

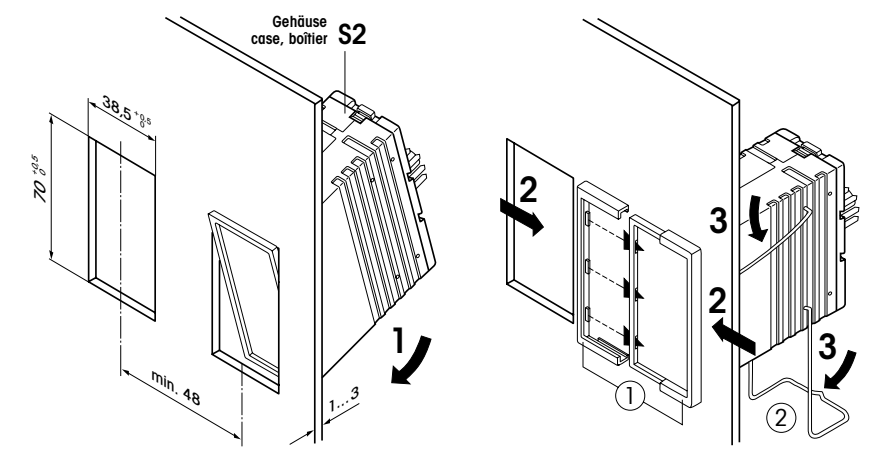

Technical drawing of the FZ-23 front of panel mounting accessory showing assembly steps. The drawing shows the assembly of the front frame parts (1) and retaining clips (2) onto the relay socket. Labels include 1, 2, 3, 1...3, and Gehäuse case, boîtier S2.